

# SECTION 11

## EROSION AND SEDIMENT CONTROL

### 11-1 CONTENTS:

*Section Item*

11-2	Definitions / Acronyms
11-3	Erosion and Sediment Control Plan
11-4	Required BMPs
11-5	Hydroseeding
11-6	Preservation of Existing Vegetation
11-7	Soil Binders
11-8	Stabilized Construction Access
11-9	Sediment Trap
11-10	Sediment Basin
11-11	Geotextiles, Plastic Covers, and Erosion Control Blankets
11-12	Silt Fence
11-13	Concrete Washout
11-14	Inlet Sediment Control Barrier
11-15	Inlet Filter Bag
11-16	Straw Mulch
11-17	Fiber Rolls

### 11-2 DEFINITIONS / ACRONYMS:

**BMP** – Best Management Practice

**NOI** – Notice of Intent

**NPDES** – National Pollutant Discharge Elimination System

**RWQCB** – Regional Water Quality Control Board

**SWPPP** – Storm Water Pollution Prevention Plan

**SWRCB** – State Water Resources Control Board

**Wet Season** – October 1st through April 30<sup>th</sup>.

**WPCP** – Water Pollution Control Program

### 11-3 EROSION AND SEDIMENT CONTROL PLAN:

Improvement Plans shall include an Erosion and Sediment Control Plan, which shall be prepared and approved per the requirements of Chapter 16.44 of Title 16 of the Sacramento County Code, Land Grading and Erosion Control Ordinance.

Erosion and Sediment Control Plans shall include erosion controls and sediment controls from this chapter to minimize erosion and the transport of sediments. These plans may be incorporated into the Grading Plans or on separate sheets for clarity.

Additionally, landowners meeting the project area disturbance threshold shall obtain coverage under the SWRCB General Permit for Storm Water Discharges Associated with Construction Activity (Construction General Permit), prior to commencing construction activities. Coverage may be obtained by filing an NOI with a vicinity map and the appropriate fee with the SWRCB.

Projects covered by the State's General Permit shall have an adequate SWPPP prepared, prior to commencing construction.

Plans shall be prepared by a civil engineer in conformance with County Specifications and shall include the following:

- A. Shed map based on 2 Ft. contours from County LIDAR topographic mapping. Shed map (scale 1":200' max.) includes project site and all off-site sheds draining onto site.
- B. Site delineation map indicating boundary lines of the property.
- C. The location of on-site and surrounding watercourses and wetlands, existing drainage systems, and drainage area boundaries and acreages. Additional hydrologic analysis shall be provided as required by the County Engineer.
- D. The location of existing roads and structures on the site, and on adjacent property, that are to remain.
- E. Accurate contours at two foot intervals for slopes up to ten percent and five foot intervals for slopes over ten percent showing topography of existing ground and locations of existing vegetation, including all oak trees, all other trees over six inches in diameter measured at four and one-half feet above the ground, groves of trees, and natural features such as rock outcroppings that are to remain. Spot elevations will be required where relatively flat conditions exist. The spot elevations or contour lines shall be extended off-site for a minimum distance of fifty (50) feet, or one hundred (100) feet in flat terrain.
- F. Elevations, location, extent and slope of all proposed grading shown by contours, cross-sections or other means, and location of any disposal areas, fills or other special features to be included in the work.
- G. A delineation of the area to be disturbed.
- H. Sub-grade, building pads, and other disturbed areas. This plan shall also include all temporary drainage features utilized during the grading phase. Any BMP's utilized during the final improvement phase (i.e. rock bags in gutter, fiber rolls behind sidewalk, etc.) are to be shown on the Grading Plan.

- I. Design all BMP's for the 5-year, 24-hour storm event. ATS (Advanced Treatment Systems) shall use the 10-year, 24-hour storm event.
- J. Cross-sections at site perimeter showing BMP's for varying boundary conditions.
- K. The location, implementation schedule, and maintenance schedule of all erosion control measures and sediment control measures to be implemented or constructed prior to, during or after the proposed activity.
- L. A description of measures designed to control dust and stabilize the construction site road and entrance.
- M. A description of the location and methods of storage and disposal of construction materials, including spoils.
- N. Current Erosion and Sediment control notes obtained from the Public Works & infrastructure.

#### **11-4 REQUIRED BMPS:**

The following BMPs shall be required on all projects:

- A. Access points to the construction site shall have a Stabilized Construction Access (Section 11-8).
- B. The preservation of existing vegetation shall be done in accordance with Preservation of Existing Vegetation (Section 11-6).
- C. Perimeter protection along property lines shall have Preservation of Existing Vegetation (Section 11-6), Silt Fence (Section 11-12) or Fiber Roll (Section 11-17).
- D. Slopes greater than 3 percent shall be temporarily seeded and slopes greater 3:1 (H:V) shall have Hydroseeding (Section 11-5) and Straw Mulch Stabilizers, Geotextiles, Plastic Covers, Straw Mulch Stabilizer, or Erosion Control Blankets (Section 11-11) installed.
- E. The toe of all slopes shall have Silt Fence (Section 11-12) and/or Fiber Roll (Section 11-17).
- F. Disturbed soil areas behind the curb or back of walk (or curb) shall have Straw Mulch (Section 11-16), Soil Binders (Section 11-7) or Geotextiles, Plastic Covers, and Erosion Control Blankets/Mats (Section 11-11) in conjunction with Hydroseeding (Section 11-5).
- G. Dead end streets, to be extended in the future, shall have Preservation of Existing Vegetation (Section 11-6), Hydroseeding (Section 11-5), Sediment Trap (Section 11-9) or other applicable BMP to minimize the transport of sediment onto or from the improved surface.
- H. Projects that include detention basins shall have a Sediment Basin (Section 11-10).

- I. Place drainage inlet sediment BMPs at all storm drain inlets. BMPs shall include Inlet Sediment Control Barrier (Section 11-14).
- J. Each construction site shall provide designated, paint and waste disposal locations as necessary.
- K. A BMP installation schedule shall be included on the improvement plans. The schedule shall include the BMPs for both the wet season and the dry season.
- L. When possible, all portable toilets shall be placed at least 50 feet from drain inlets and anchored down to prevent being tipped over.

**11-5 HYDROSEEDING:**

- A. **Definition** – The application of a mixture of fiber, seed, fertilizer, and stabilizing product with hydro-mulch equipment, which temporarily protects exposed soils from erosion by wind and water.
- B. **Applicability** – Hydroseeding shall be applied in the following conditions:
  - 1. Graded or cleared areas subject to erosion from wind or water.
  - 2. As perimeter control along property lines where existing vegetation does not exist.

If slopes to be hydroseeded are steeper than 3:1 (H:V), hydroseeding shall be used in combination with matting, mulch, or other soil stabilizer.

- C. **Design** – Areas to be hydroseeded shall be clearly identified on the plans. Application shall conform to the following:
  - 1. **Timing** – Hydroseeding shall be implemented in advance of the time when there is risk of erosion. To protect areas by October 1, hydroseeding shall be implemented no later than September 15. Hydroseeding applied after October 1 and before April 30 shall be covered with straw mulch, soil binder, or erosion control blanket/mat.
  - 2. Adjacent to wetlands and environmentally sensitive areas, the minimum width of a vegetated area draining into the affected area shall be 100 feet for slopes of 20:1 (H:V) or flatter. When slopes are steeper than 20:1 (H:V), additional measures shall be used as determined by the County Engineer. Adjacent to improvements, the minimum width shall be 20 feet.
- D. **Maintenance**
  - 1. All slopes shall be maintained to prevent erosion.
  - 2. Seeded areas shall be inspected for failures and re-seeded, fertilized, and mulched within the planting season. Any temporary revegetation efforts that do not provide adequate cover must be revegetated as required by the County Engineer.

## 11-6 PRESERVATION OF EXISTING VEGETATION

- A. **Definition** – The maintaining of areas of existing vegetation to utilize stable vegetated areas to reduce the amount of sediment in sheet flow runoff and to minimize the extent of disturbed area.
- B. **Applicability** – Preservation of existing vegetation shall be used when currently vegetated areas can be integrated into the proposed project. Examples where existing vegetation shall be applicable include:
1. Buffer strips adjacent to wetlands and other sensitive areas.
  2. As perimeter protection along property lines.
  3. Undeveloped portions of a job site.
- C. **Design**
1. Areas of vegetation to be preserved shall be clearly marked on plans and fenced or flagged in the field.
  2. Traffic and stockpiles shall be located away from vegetated areas. Irrigation and maintenance shall be specified on the plans.
  3. For appropriate widths of vegetated areas, refer to the specifications for hydroseeding (Section 11-5).
- D. **Maintenance** – Irrigation and maintenance requirements shall be specified on the plans. Irrigation shall be provided as needed to maintain the vegetation year round.

## 11-7 SOIL BINDERS

- A. **Definition** – The application and maintaining of polymeric or lignin sulfonate stabilizers or emulsions. Soil binders are materials applied to the soil surface to temporarily prevent wind or water-induced erosion of exposed soils.
- B. **Applicability** – Soil binders are applied to disturbed areas requiring short-term temporary protection.
- C. **Design**
1. Soil binders are temporary in nature and may need reapplication.
  2. Soil binders shall be applied a minimum of 24 hours prior to a rainfall. Applications during or immediately prior to a rainfall will not be permitted.
  3. Soil binders shall be environmentally friendly (non-toxic to plant and animal life) and shall not stain or discolor paved or painted surfaces.
  4. Selection and application of soil binders shall be in accordance with the manufacturer's recommendations and specifications.
- D. **Maintenance**
1. Avoid vehicular and pedestrian traffic on treated areas.

2. Inspect high traffic areas daily. Low traffic areas should be inspected weekly. During wet weather inspections should be completed daily and logged in the SWPPP maintenance log.
3. Failed slopes shall be repaired immediately.
4. Reapply soil binder as necessary for proper maintenance.

## 11-8 STABILIZED CONSTRUCTION ACCESS

- A. **Definition** – A stabilized access consisting of a pad of coarse aggregate underlain with filter cloth located where traffic enters or leaves a construction site to minimize tracking of sediment from a construction site onto paved streets.
- B. **Applicability** – A stabilized construction access shall be applied at the following locations where construction traffic enters or leaves:
  1. Paved public streets, sidewalks and rights-of-way.
  2. Parking lots or other paved areas.
- C. **Design**
  1. Placement of stabilized construction access shall be clearly defined on the improvement plans.
  2. The stabilized construction site access shall be constructed per detail 11-1.
  3. This practice shall be supported by a tire wash area and street sweeping. The County Engineer may require a tire wash area where site conditions necessitate BMP measures beyond the stabilized construction access.
- D. **Maintenance**
  1. Inspect stabilized construction access daily for damage and effectiveness of preventing soil, sediment, and construction debris from being tracked onto public streets. Streets adjacent to stabilized construction access areas shall be swept daily to remove loose materials.
  2. Remove aggregate, separate, and disposed of sediment if construction access is clogged with sediment or as directed by the County inspector.

## 11-9 SEDIMENT TRAP

- A. **Definition** – A small temporary basin formed by excavation to intercept and detain the sediment laden runoff to allow the sediment to settle. It is used to protect other drainage facilities and properties downstream of the sediment trap.
- B. **Applicability** – There are two types of sediment traps:
  1. Sediment traps suitable for drainage areas of less than 5 acres.
  2. Sediment traps shall *not* be applied in the following conditions:

The drainage area is greater than 5 acres.

In a creek or stream.

Uphill from a street or utility trench.

In areas subject to trespass.

**C. Design**

1. Placement of a sediment trap shall be clearly defined on the plans.
2. Sediment traps shall be constructed as the first step when there is mass clearing or grading and shall be located at the point where drainage discharges from a site.
3. Construction of sediment traps shall be per details 11-2 and 11-3.
4. The trap storage volume shall be designed for 35 cubic yards per acre of contributing drainage area.
5. Side slopes shall be 3:1 (H:V) or flatter and the maximum depth shall be 3.5 feet.
6. The length of a sediment trap shall be 2 times (minimum) its width.

**D. Maintenance**

1. Trap maintenance shall be year round. Sediment material shall be removed from the bottom to retain one foot of capacity at all times.
2. Trap slopes shall be kept in good repair. Slope failures or damage shall be repaired promptly.

## **11-10 SEDIMENT BASIN**

- A. **Definition** – A temporary basin formed by excavation to intercept and detain sediment laden runoff to allow the sediment to settle. It is used to protect other drainage facilities and properties downstream of the sediment basin.
- B. **Applicability** – Sediment basins are suitable for incorporating into the construction of permanent facilities designed for flood control and water quality.

Sediment basins shall *not* be applied in the following conditions:

1. In a creek or stream.
2. Where the project site can be broken up into small drainage areas 10 acres or less where sediment traps can be used.
3. Where failure can cause property damage or loss of life.
4. In areas subject to trespass unless they are secured.

C. **Design** – Basins shall be located, sized and configured based on site-specific conditions. All basin designs are subject to approval by the County Engineer. In addition to County Standards the sediment basins shall meet the minimum requirements of the State’s General Construction Permit.

1. Basin sizing shall be in accordance with one of the three (3) following options:

a. Sediment basin(s), as measured from the bottom of the basin to the principal outlet, shall have at least a capacity equivalent to 3,600 cubic feet of storage per acre draining into the sediment basin. The length of the basin shall be more than twice the width of the basin. The length is determined by measuring the distance between the inlet and the outlet, and the depth must not be less than three feet nor greater than five feet for safety reasons and for maximum efficiency.

b. Sediment basin(s) shall be designed using the standard equation:

$$A_s = 1.2 Q/V_s$$

Where:  $A_s$  is the minimum surface area for trapping soil particles of a certain size;  $V_s$  is the settling velocity of the design particle size chosen; and  $Q = CxIx A$  where  $Q$  is the discharge rate measured in cubic feet per second;  $C$  is the runoff coefficient;  $I$  is the intensity for the 5 year, 24 hour rain event and  $A$  is the area draining into the sediment basin in acres. The design particle size shall be the smallest soil grain size determined by wet sieve analysis, or the fine silt sized (0.01 mm) particle, and the  $V_s$  used shall be 100 percent of the calculated settling velocity.

The length is determined by measuring the distance between the inlet and the outlet; the length shall be more than twice the dimension as the width; the depth shall not be less than three feet nor greater than five feet for safety reasons and for maximum efficiency (two feet of storage, two feet of capacity). The basin(s) shall be located on the site where it can be maintained on a year round basis and shall be maintained on a schedule to retain the two feet of capacity.

c. The use of an equivalent surface area design or equation provided that the design efficiency is as protective of water quality than option b.

2. Basins for drainage areas larger than 75 acres shall be approved by the County Engineer.

3. Sediment basins shall be fenced where safety (worker or public) is a concern, or as indicated by the County Engineer.

D. **Maintenance**

1. Basin maintenance shall be year round. Sediment material shall be removed from the bottom to retain two feet of capacity at all times.



2. Basin slopes shall be kept in good repair. Slope failures or damage shall be repaired promptly.
3. Basins shall have a means for dewatering within 7-calendar day following a storm event.

## **11-11 GEOTEXTILES, PLASTIC COVERS, AND EROSION CONTROL BLANKETS/MATS**

- A. **Definition** – This Best Management Practice (BMP) involves the placement of geotextiles, plastic covers, or erosion control blankets/mats to stabilize disturbed soil areas and protect soils from erosion by wind and water.
- B. **Applicability** – Use these surface BMPs when disturbed soils may be difficult to stabilize.
- C. **Design** –
  1. Use on steep slopes, generally steeper than 3:1 (H:V).
  2. Cover material and soil stock piles during rainfall events.
  3. Use on channels to be vegetated.
  4. Installation shall be in accordance with the manufacturers recommendation.
  5. Geotextile material shall be woven polypropylene fabric with minimum thickness of 15 mm, minimum width of 3.7 m and shall have a minimum tensile strength of 0.67 kN (warp) and 0.36 kN (fill) in conformance with the requirements of ASTM Designation: D4632. The permittivity of the fabric shall be approximately  $0.07 \text{ sec}^{-1}$  in conformance with the requirements in ASTM Designation : D4491. The fabric shall have an ultraviolet (UV) stability of 70 percent in conformance with the requirements in ASTM designation: D4355.
  6. Geotextile blankets shall be secured in place with wire staples or sandbags and by keying into tops of slopes to prevent infiltration of surface waters under Geotextile material.
  7. Plastic cover material shall be polyethylene sheeting and shall have a minimum thickness of 6 mils. Plastic covers shall be anchored by sand bags placed no more than 10 ft. apart and by keying into the tops of slopes to prevent infiltration of surface waters under the plastic. All seams shall be taped or weighted down their entire length, and there shall be at least a 12 in. to 24 in. overlap of all seams.
  8. Erosion control blankets/mats shall be either straw, coconut, straw/coconut or excelsior blanket. Grade and shape the area of installation. Remove all rocks, clods, vegetation or other obstructions so that the installed blankets or mats will have complete, direct contact with the soil. Blankets/mats shall be

anchored with U-shaped wire staples, metal geo-textile stake pins or triangular wooden stakes. Staples shall be made of 3.05 mm steel wire and shall be U-shaped with 200-mm legs and 50mm crown. Wire staples shall be minimum of 11 gauge. Metal stake pins shall be 0.188 in. diameter steel with a 1.5 in. steel washer at the head of the pin. Wire staples and metal pins shall be driven flush to the soil surface. All anchors shall be 6 in. to 18 in. long and have sufficient ground penetration to resist pullout.

9. Channels constructed during the wet season (October 1 through April 30) shall protect the channel sides and bottom with erosion control blankets/mats as shown in detail 11-9.
10. Channel bottoms shall be protected where the design channel flow exceeds 3 ft/sec.

**D. Maintenance**

1. All blankets shall be inspected periodically after installation.
2. Inspect installations after significant rainfalls to check for erosion and undermining. Repair failures immediately. Damage to slopes or channels shall be repaired prior to reinstalling blankets/mats.

## **11-12 SILT FENCE**

A. **Definition** – A barrier of extra strength filter fabric which has been entrenched and attached to supporting posts to reduce runoff velocity and detain sediment.

B. **Applicability** – Silt fences are used near disturbed areas where sheet or rill flows occur and velocities are low. Silt fences are placed below the toe of exposed and erodible slopes, down-slope of exposed soil areas, around temporary stockpiles and along streams and channels. Silt fences shall **not** be applied in the following conditions:

1. In the flowline of streams, channels, or anywhere flows are concentrated.
2. Drainage areas of 1 acre or more.
3. Where the slope is steeper than 2:1 (H:V).
4. Slopes that are subject to creep, slumping, or landslides.
5. Mid-slope installations where slope exceeds 4:1 (H:V).

**C. Design**

1. Placement of a silt fence shall be clearly shown on the plans.
2. Construction shall be per County of Sacramento Standard Construction Specifications Drawing 11-5.
3. The maximum slope length above the fence shall be no more than 30 feet times the slope steepness expressed as a ratio. For example, a 4:1 (H:V)

slope above a fence shall be no more than 120 feet long. The maximum slope distance between silt fences, regardless of slope, shall be 200 feet.

4. The depth of flow shall be evenly distributed across the fence.
5. Silt fences shall be trenched in and the bottom of the fence fabric shall be keyed in.
6. The fence shall be placed on the contour and configured in the shape of a shallow arc with the ends uphill of the arc's center. It shall be constructed in a length sufficient to extend across the expected flow path.

**D. Maintenance**

1. Repair or replace split, torn, slumping or weathered fabric.
2. Inspect silt fences when rain is forecast and again after rainfall events.
3. Sediment shall be removed from behind the silt fence when sediment accumulation is 1/3 the height of the barrier or when sediment accumulation is causing the silt fence to fail.

## **11-13 CONCRETE WASHOUTS**

A. **Definition** – Procedures and practices that are implemented to minimize or eliminate the discharge of concrete waste materials to the storm drain system or to watercourses.

B. **Applicability** – Concrete washouts are to be placed on project sites where concrete is used as a construction material, where slurries containing portland cement concrete (PCC) or asphalt concrete are generated, or where concrete trucks and other concrete-coated equipment are washed on site.

**C. Design**

1. Temporary concrete washout facilities shall be located a minimum of 50 ft. from storm drain inlets, open drainage facilities, and watercourses.
2. A sign shall be installed adjacent to each washout facility to inform concrete equipment operators of its location. Signs shall be placed on construction sites providing direction to the concrete washout.
3. Installation shall be per drawing 11-6.
4. Plastic lining material shall be a minimum of 60 mil polyethylene sheeting and shall be free of holes, tears or other defects that compromise the impermeability of the material.
5. Concrete washouts constructed below grade shall have a minimum depth of 12 inches and have a surface area of 50 square feet.

**D. Maintenance**

1. Inspect concrete washouts daily.

2. Concrete washouts shall be maintained to provide holding capacity with a minimum freeboard of 4 inches. Hardened concrete shall be removed and disposed of properly and the washout facilities returned to a functional condition.
3. Concrete washouts shall be cleaned when the waste volume in the washout reaches 75 percent of capacity.

## **11-14 INLET SEDIMENT CONTROL BARRIER**

- A. **Definition** – A temporary sediment barrier placed in the gutter or on the surface adjacent to a drainage inlet to reduce the velocity of the storm water runoff prior to entering the inlet structure. Inlet sediment control devices shall cause the storm water to pond and provide sediment removal prior to entering the inlet.
- B. **Applicability** – Inlet sediment control devices shall be installed on the upstream side of drainage inlets. For inlets in gutter low points, inlet sediment control devices shall be installed on both sides of the inlet. Devices shall be installed at a minimum of three (3) feet from the inlet.
- C. **Design**
  1. Sediment control devices shall be designed to allow maintenance of the device and regular removal of trapped sediments.
  2. Within traveled ways, vehicular and pedestrian, devices shall be selected and installed so that they do not constitute a hazard.
  3. Inlet sediment control devices may consist of gravel bags or other approved sediment control device which provides effective sediment removal.
  4. Install per detail 11-7.
  5. Inlet sediment devices shall remain in place until soil disturbing activities are completed and adjacent areas are stabilized.
- D. **Maintenance**
  1. Inlet sediment control devices shall be kept in good repair. Material spilling from sediment control devices shall be cleaned up and device repaired or replaced immediately.
  2. Inspection of devices shall be weekly and prior to predicted rainfall and after the rainfall event. Sediment removed from sediment devices during maintenance operations shall be disposed of properly.

## **11-15 INLET FILTER BAG**

- A. **Definition** – A temporary sediment barrier suspended within a storm drain drop inlet to prevent sediment and debris from entering the storm drainage system.

- B. **Applicability** – Inlet filter bags are not allowed.

## 11-16 STRAW MULCH

- A. **Definition** – Placing a uniform layer of straw and incorporating it into the soil with a studded roller or anchoring it with a tackifier.
- B. **Applicability** – Straw mulch is used for temporary soil stabilization on disturbed areas until soils can be prepared for re-vegetation and permanent vegetation is established. Straw mulch is also used in temporary and permanent seeding strategies to enhance plant establishment.
- C. **Design**
  - 1. Straw shall be derived from wheat, rice, or barley.
  - 2. Straw mulch with tackifier shall not be applied during or immediately prior to rainfall.
  - 3. Tackifier is the preferred method for anchoring straw mulch to the soil on slopes. Crimping, punch roller-type rollers, or track-walking may also be used.
  - 4. Apply loose straw at a minimum rate of 4,000 lb/ac.
  - 5. Apply tackifier at a minimum rate of 125 lb/ac.
- D. **Maintenance**
  - 1. Reapplication of straw mulch and tackifier may be required by the County Engineer to maintain effective soil stabilization over disturbed areas and slopes.
  - 2. Slopes shall be maintained and repaired immediately after any rainfall event.

## 11-17 FIBER ROLL

- A. **Definition** – A fiber roll consists of straw, flax, or other material that are rolled and bound into a tight tubular roll and placed on the face of slopes at regular intervals or behind curbs and walkways to intercept storm water runoff, reduce its velocity, release the runoff as sheet flow, and provide some removal of sediment from the runoff.
- B. **Applicability** – Fiber rolls may be used along the top, face and at grade breaks of exposed and erodible slopes, placed behind curbs or walkways, and used as check dams when properly anchored.
- C. **Design**
  - 1. On slopes fiber rolls shall be placed along the contour. At the ends of the row, the last two feet shall be turned up slope slightly.

2. Fiber rolls shall be manufactured and have a minimum density of 1.1 lbs/lf. Use and installation of fiber rolls shall be in accordance the manufacturer's recommendation. Fiber rolls shall be wrapped with biodegradable material.
3. When more than one fiber roll is placed in a row, the ends of the rolls shall be butted together tightly, or overlapped a minimum of 1ft.
4. Fiber rolls used as check dams shall be trenched and staked such that water is not allowed to flow under the rolls.
5. Install per detail 11-4.

**D. Maintenance**

1. Repair or replace split, torn, unraveling, or slumping fiber rolls.
2. Inspect fiber rolls when rain is forecast.
3. In active construction areas where fiber rolls are removed during the work day, return or replace the fiber roll to its proper place and stake it down at the end of each workday during the wet season.

—

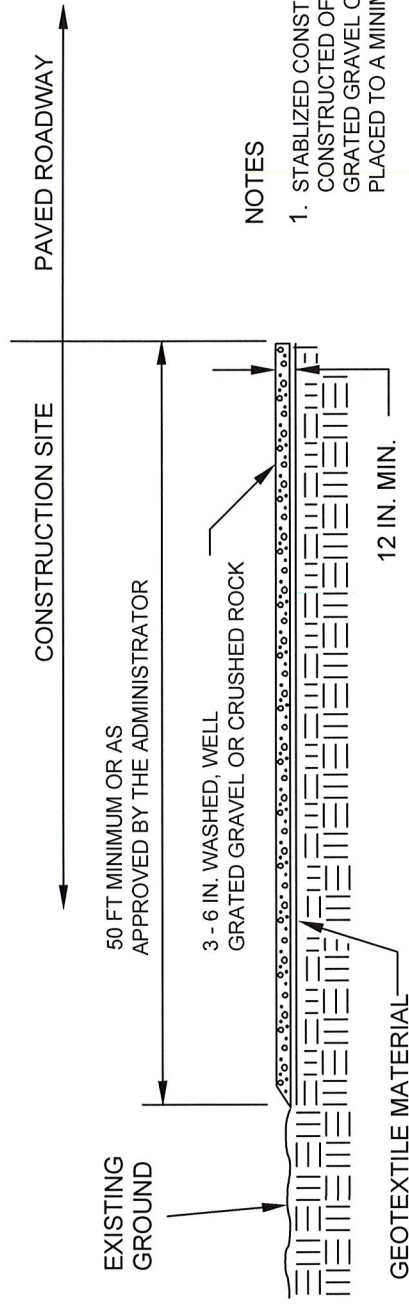

**SECTION A-A**

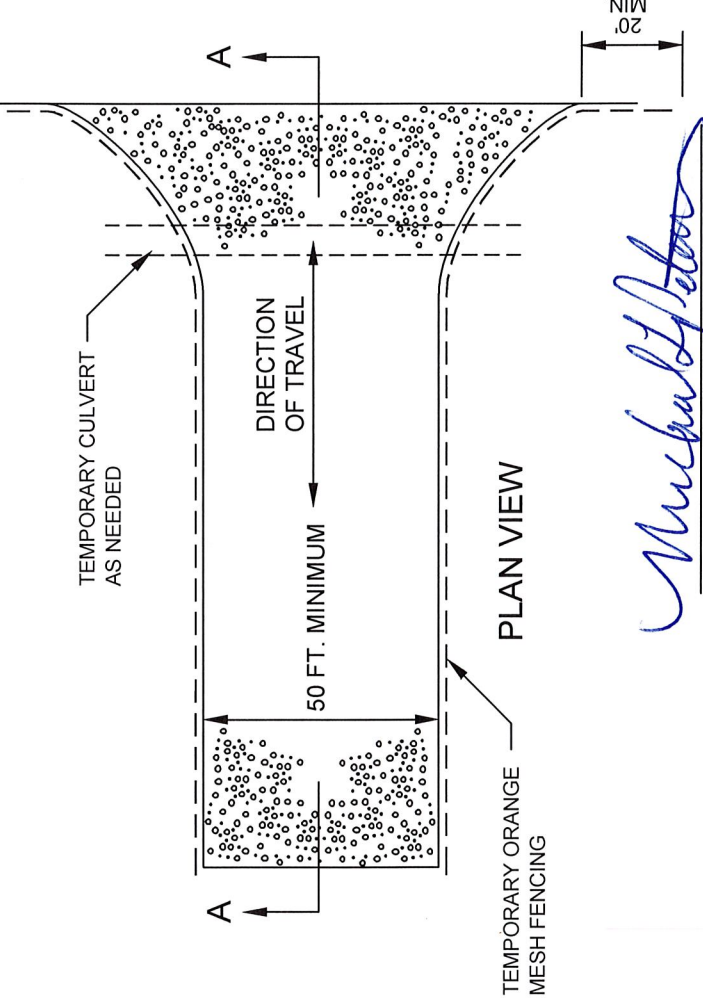

**NOTES**

1. STABILIZED CONSTRUCTION SITE ACCESS SHALL BE CONSTRUCTED OF 3-6 INCH WASHED, WELL GRATED GRAVEL OR CRUSHED ROCK. MATERIAL SHALL BE PLACED TO A MINIMUM THICKNESS OF 12 INCHES.
2. LENGTH OF ENTRANCE SHALL BE A MINIMUM OF 50 FT. WIDTH SHALL BE A MINIMUM OF 10 FT. OR GREATER IF NECESSARY TO COVER ALL VEHICULAR INGRESS AND EGRESS. PROVIDE AMPLE TURNING RADII.
3. THE ENTRANCE SHALL BE KEPT IN GOOD CONDITION BY OCCASIONAL TOP DRESSING WITH MATERIAL AS SPECIFIED IN NOTE 1.
4. ACCESSES SHALL BE INSPECTED DAILY DURING PERIODS OF HEAVY USAGE, WEEKLY DURING NORMAL USAGE, AND AFTER EACH RAINFALL, WITH MAINTENANCE PROVIDED AS NECESSARY. PERIODIC TOP DRESSING SHALL BE DONE AS NEEDED.

SACRAMENTO COUNTY MUNICIPAL SERVICES AGENCY	
<b>STABILIZED CONSTRUCTION SITE ACCESS</b>	
SCALE: NONE DATE: REV. MAR 2014 DRAWN BY: AW	<b>11-1</b>

*Michael J. Peterson*  
DIRECTOR, DEPT. OF WATER RESOURCES

THIS DRAWING SUPERCEDES ALL PREVIOUS VERSIONS

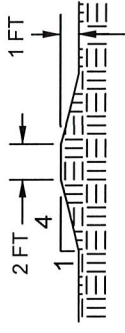
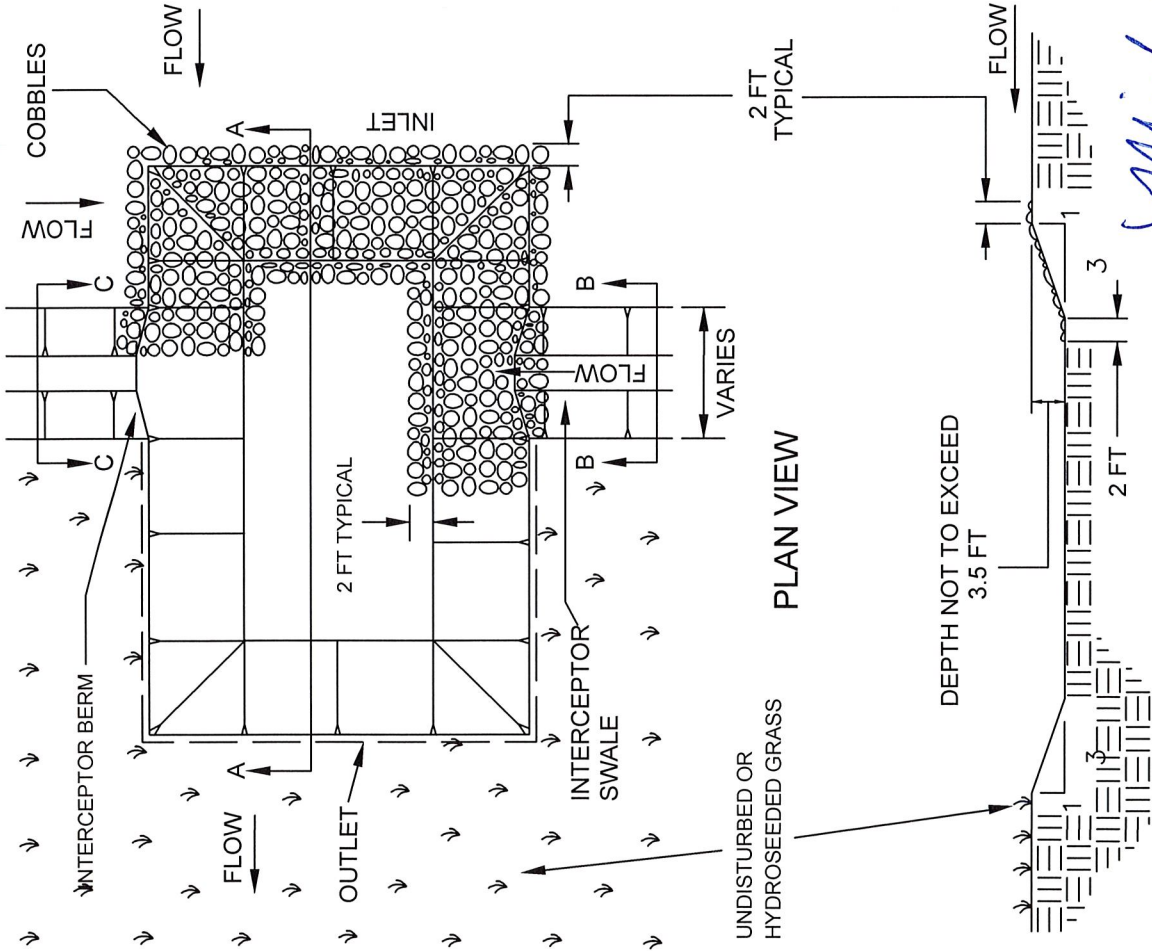

**SECTION B-B**

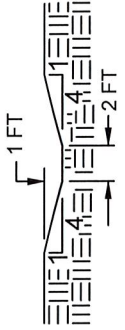

**SECTION C-C**

**NOTES**

1. DIMENSIONS OF SEDIMENT TRAPS, DIKES AND SWALES SHALL BE APPROVED BY THE ADMINISTRATOR.
2. INTERCEPTION DIKES AND SWALES SHALL BE CONSTRUCTED TO DRAIN SURFACE RUNOFF INTO SEDIMENT TRAPS.
3. TRAPS SHALL BE EXCAVATED WITH APPROPRIATE EQUIPMENT, TAKING CARE NOT TO DISTURB VEGETATION OR SOIL AT OUTLET CREST. SIDE SLOPES SHALL BE 3:1 OR FLATTER. MAXIMUM TRAP DEPTH SHALL BE 3.5 FT.
4. COBBLES CONFORMING TO COUNTY STANDARD SPECIFICATIONS SHALL BE PLACED ON THE TOPS, SLOPES, AND BOTTOMS OF THE INLET SIDES. COBBLES SHALL EXTEND A MINIMUM OF 2 FT BEYOND THE TOP AND TOE OF SLOPES.
5. PERIMETER OF THE SEDIMENT TRAP SHALL BE HYDROSEEDDED 3 METERS (10 FEET) BEYOND EDGE OF EXCAVATION IF EXISTING VEGETATION IS THIN, DISTURBED, OR NONEXISTENT.
6. THE CONTRACTOR SHALL INSPECT SEDIMENT TRAPS WEEKLY AND AFTER EACH RAINFALL AND REPAIR AS NECESSARY. SEDIMENT SHALL BE REMOVED FROM THE BOTTOM OF THE TRAP WHEN 1 FT DEEP OR LESS.

*Michael J. Peter*  
 DIRECTOR, DEPT OF WATER RESOURCES

**SECTION A-A**

THIS DRAWING SUPERCEDES ALL PREVIOUS VERSIONS

SACRAMENTO COUNTY MUNICIPAL SERVICES AGENCY	
<b>SEDIMENT TRAP VEGETATED OUTLET</b>	
SCALE: NONE DATE: REV. MAR 2014 DRAWN BY: AW	<b>11-2</b>



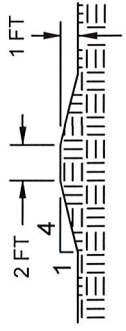
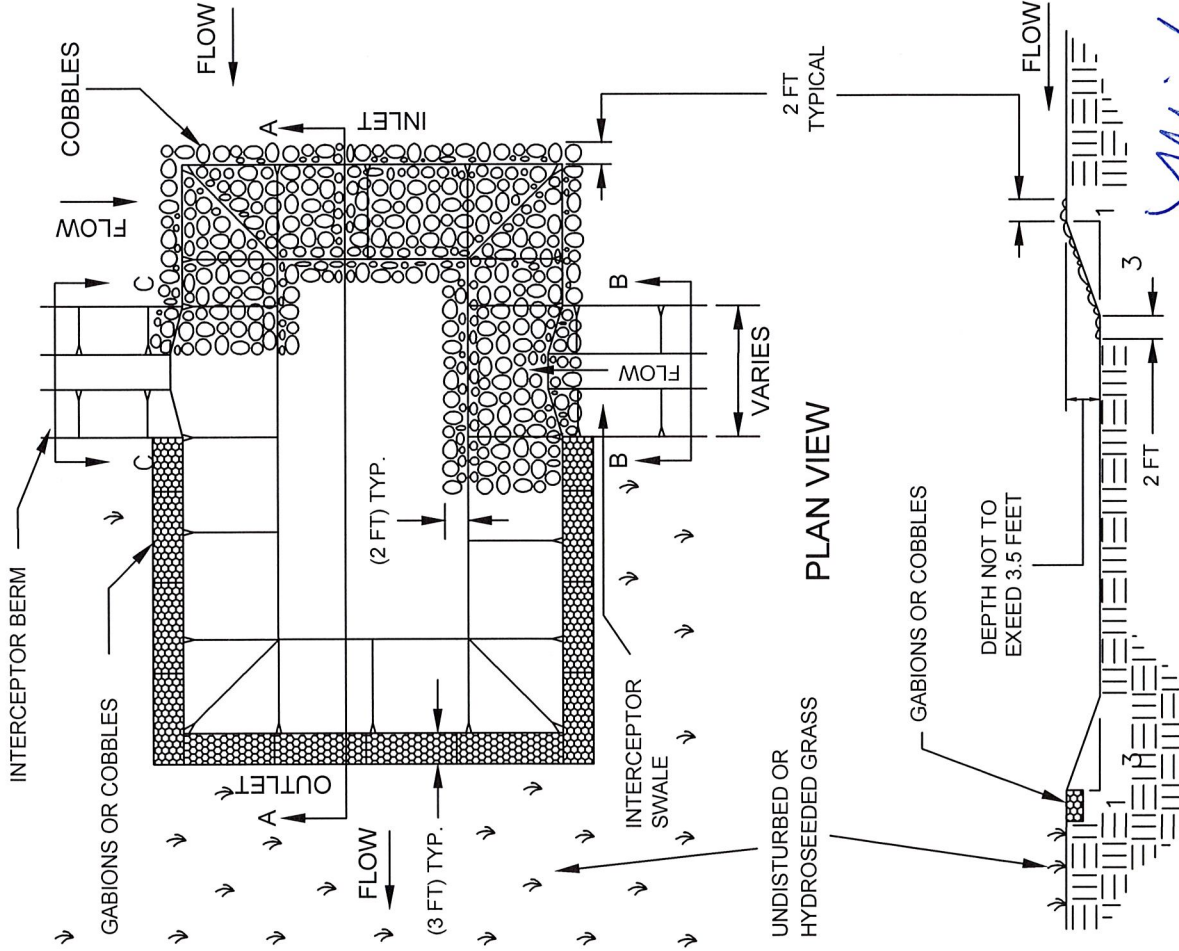

SECTION B-B

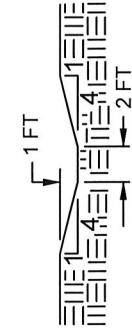

SECTION C-C

NOTES

1. DIMENSIONS OF SEDIMENT TRAPS, DIKES, AND SWALES SHALL BE APPROVED BY THE ADMINISTRATOR.
2. INTERCEPTION DIKES AND SWALES SHALL BE CONSTRUCTED TO DRAIN SURFACE RUNOFF INTO SEDIMENT TRAPS.
3. TRAPS SHALL BE EXCAVATED WITH APPROPRIATE EQUIPMENT, TAKING CARE NOT TO DISTURB VEGETATION OR SOIL AT OUTLET CREST. SIDE SLOPES SHALL BE 3:1 OR FLATTER. MAXIMUM TRAP DEPTH SHALL BE 3.5 FEET.
4. COBBLES CONFORMING TO COUNTY STANDARD SPECIFICATIONS SHALL BE PLACED ON THE TOPS, SLOPES, AND BOTTOMS OF THE INLET SIDES. COBBLES SHALL EXTEND A MINIMUM OF 600 MM (2 FEET) BEYOND THE TOP AND TOE OF SLOPES.
5. PERIMETER OF SEDIMENT TRAPS SHALL BE STABILIZED WITH GABIONS OR COBBLES AND HYDROSEED 3 METERS (10 FEET) BEYOND EDGE OF EXCAVATION IF EXISTING VEGETATION IS THIN, DISTURBED OR NONEXISTENT.
6. THE CONTRACTOR SHALL INSPECT SEDIMENT TRAPS WEEKLY AND AFTER EACH RAINFALL AND REPAIR AS NECESSARY. SEDIMENT SHALL BE REMOVED FROM THE BOTTOM OF THE TRAP WHEN 1 FOOT DEEP OR LESS.

SACRAMENTO COUNTY  
MUNICIPAL SERVICES AGENCY

SEDIMENT TRAP  
STABILIZED OUTLET

SCALE: NONE  
DATE: REV. MAR 2014  
DRAWN BY: AW

11-3

*Michael J. Peters*  
DIRECTOR, DEPT. OF WATER RESOURCES

THIS DRAWING SUPERCEDES ALL PREVIOUS VERSIONS

SECTION A-A

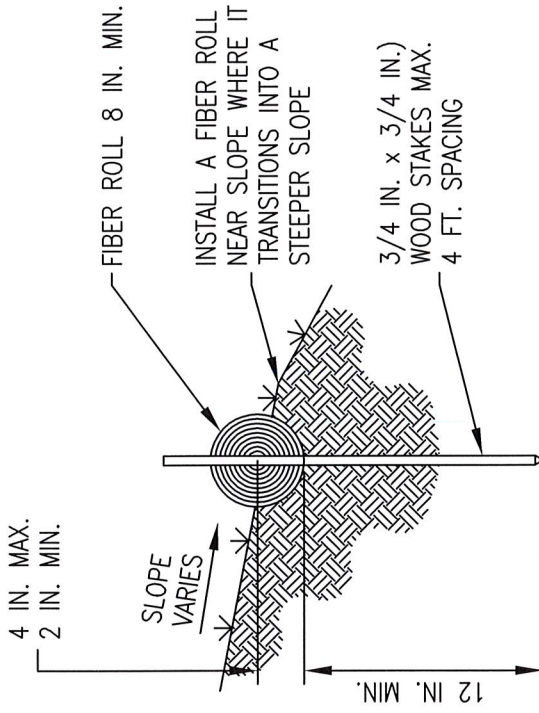
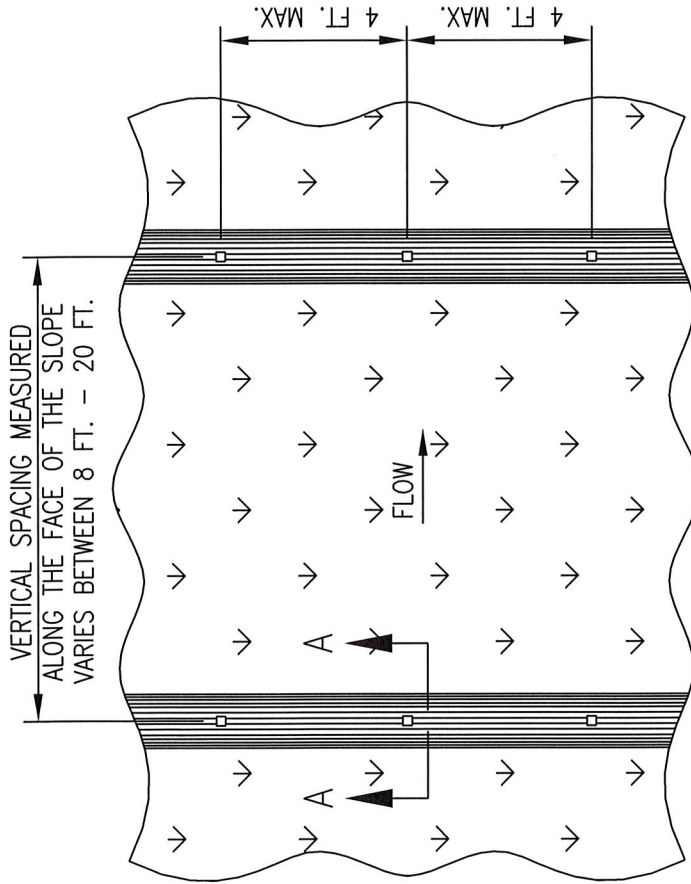

TYPICAL FIBER ROLL INSTALLATION

SECTION A - A

NOTES:

- 1.) INSTALL FIBER ROLLS IN A ROW ALONG A LEVEL CONTOUR.
- 2.) AT ENDS OF A ROW TURN THE LAST TWO FEET UP SLOPE SLIGHTLY.
- 3.) FIBER ROLLS SHALL BE OVERLAPED TIGHTLY AT THE JOINTS, NOT ABUTTED.

*Michelle Peters*  
 DIRECTOR, DEPT. OF WATER RESOURCES

SACRAMENTO COUNTY  
 MUNICIPAL SERVICES AGENCY

**FIBER ROLLS**

DRAWN BY: AW  
 SCALE: NONE  
 DATE: REV. MAR 2014

NOTES:

- 1.) CONSTRUCT THE LENGTH OF EACH REACH SO THAT THE CHANGE IN BASE ELEVATION ALONG THE REACH DOES NOT EXCEED 1/3 THE HEIGHT OF THE LINEAR BARRIER. IN NO CASE SHALL THE REACH LENGTH EXCEED 150M.
- 2.) THE LAST 8 FT. OF FENCE SHALL BE TURNED UP SLOPE.
- 3.) STAKE DIMENSIONS ARE NOMINAL.
- 4.) DIMENSIONS MAY VARY TO FIT FIELD CONDITION.
- 5.) STAKES SHALL BE SPACED AT 8 FT. MAXIMUM AND SHALL BE POSITIONED ON THE DOWNSTREAM SIDE OF THE FENCE.
- 6.) OVERLAP STAKES, AND FOLD FENCE FABRIC TO AROUND EACH STAKE ONE FULL TURN.
- 7.) STAKES SHALL BE DRIVEN TIGHTLY TOGETHER TO PREVENT POTENTIAL FLOW THROUGH OF SEDIMENT AT THE JOINT.
- 8.) FOR END STAKE CONDITION FOLD FENCE FABRIC AROUND (2) STAKES (1) FULL TURN AND SECURE WITH (4) STAPLES. MINIMUM (4) STAPLES PER STAKE.
- 10.) CROSS BARRIERS SHALL BE A MINIMUM OF 1/3 AND A MAXIMUM OF 1/2 THE HEIGHT OF THE LINEAR BARRIER.
- 11.) BOTTOM OF SILT FENCE SHALL BE KEYED-IN A MINIMUM OF 12".

*Mitchell J. Helms*  
 DIRECTOR, DEPT. WATER RESOURCES

SACRAMENTO COUNTY  
 MUNICIPAL SERVICES AGENCY

**SILT FENCE**

DRAWN BY: AW  
 SCALE: NONE  
 DATE: REV. MAR 2014

**11-5**

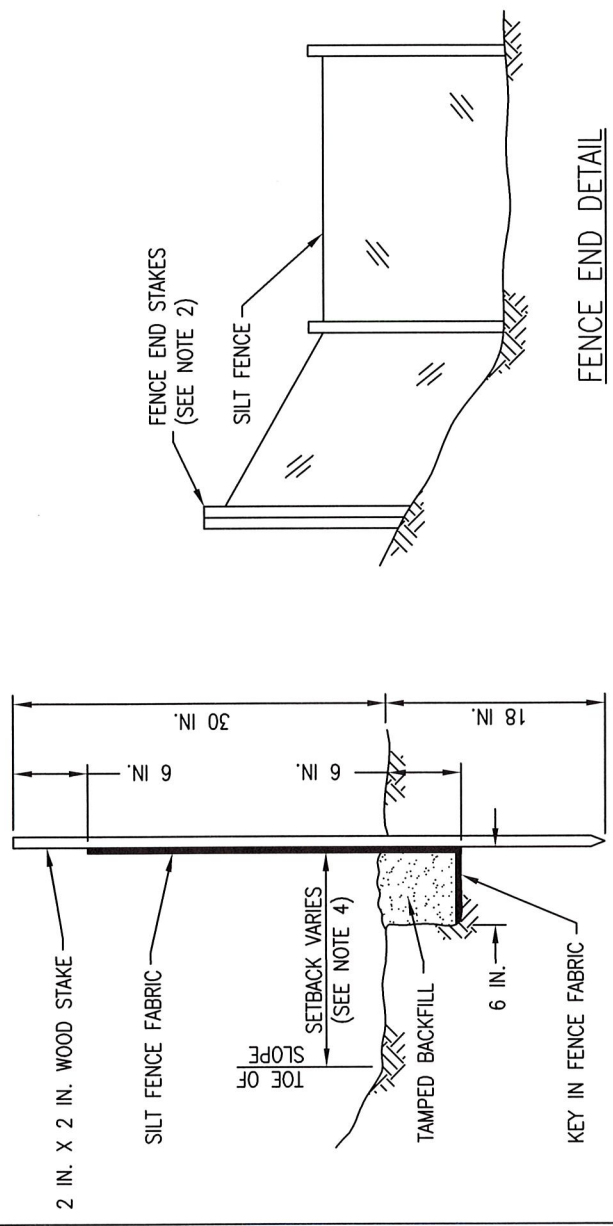

FENCE END DETAIL

FENCE SECTION DETAIL

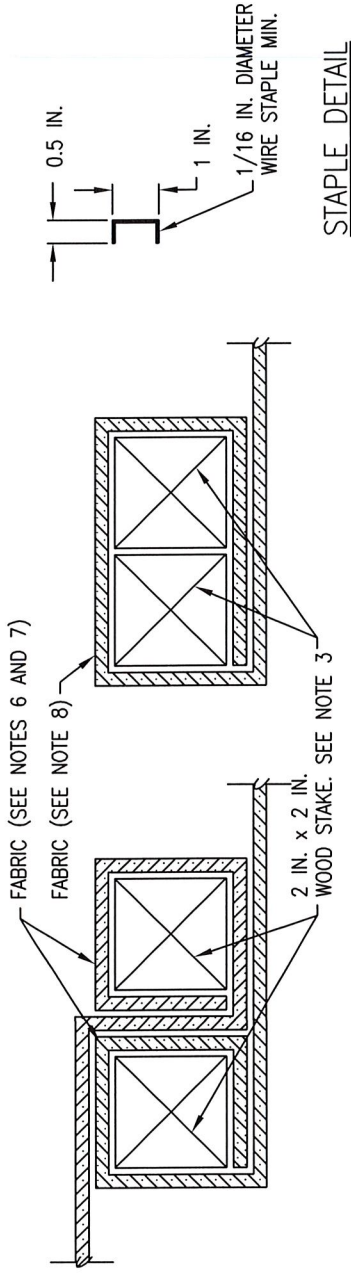

JOINT DETAIL

END STAKE DETAIL

STAPLE DETAIL



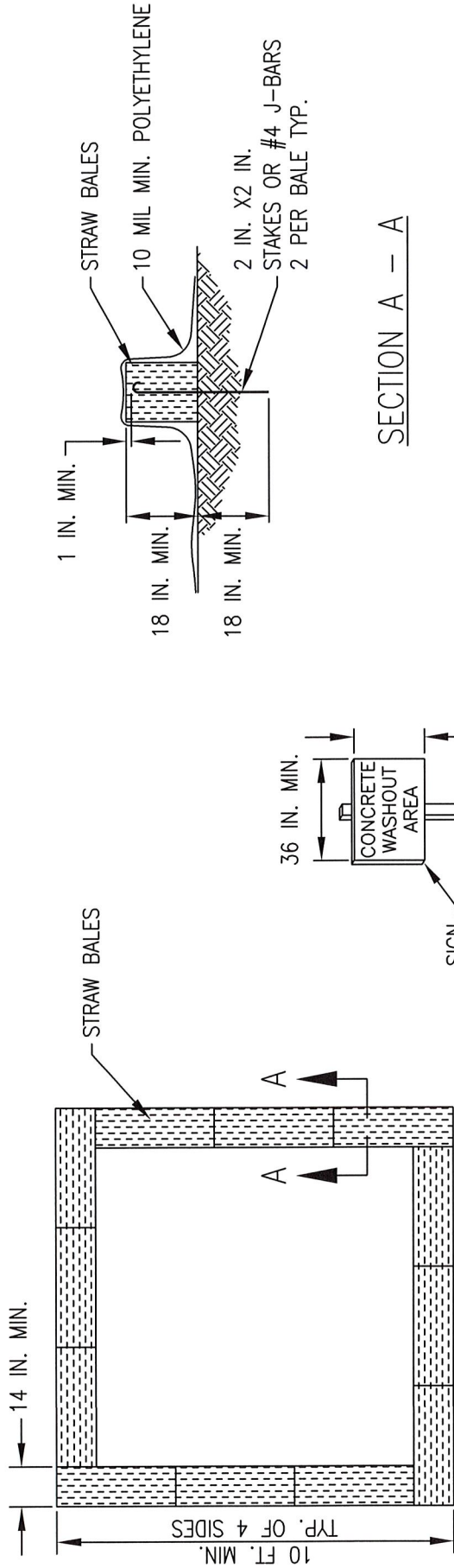

BALE CONFIGURATION

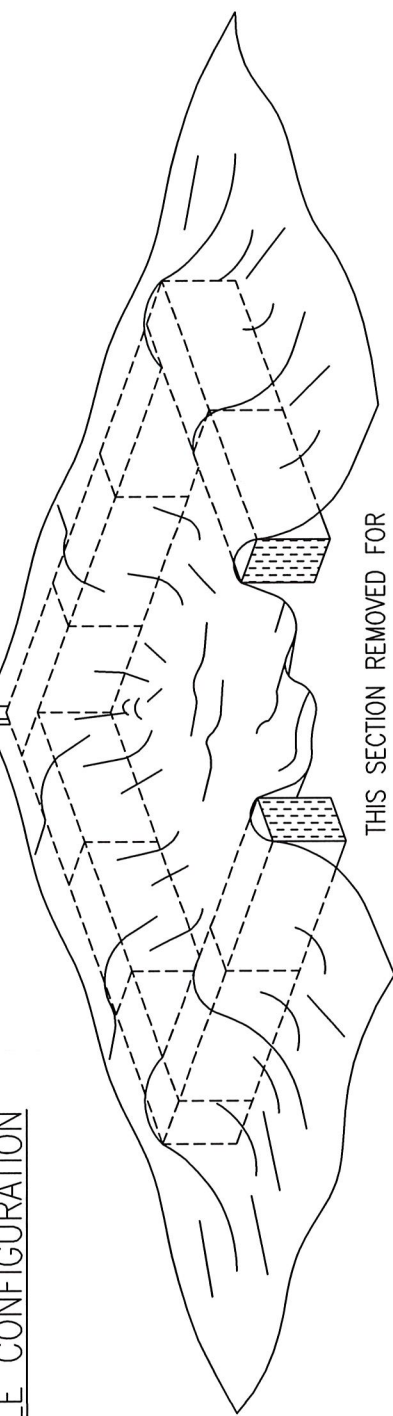

THIS SECTION REMOVED FOR GRAPHICAL REPRESENTATION ONLY. STRAW BALE PERIMETER SHALL BE CONTINUOUS.

- NOTES:
- 1.) FACE SIGN TOWARD NEAREST STREET OR ACCESS POINT.
  - 2.) CONCRETE WASHOUT SHALL BE LOCATED BEHIND THE CURB AND 50 FT. MINIMUM FROM DRAINAGE INLETS OR WATERCOURSES

SACRAMENTO COUNTY  
MUNICIPAL SERVICES AGENCY

**CONCRETE WASHOUT**

DRAWN BY: AW  
SCALE: NONE  
DATE: REV. MAR. 2014

**11-6**

*Mickal Y. Peters*

DIRECTOR, DEPT. WATER RESOURCES

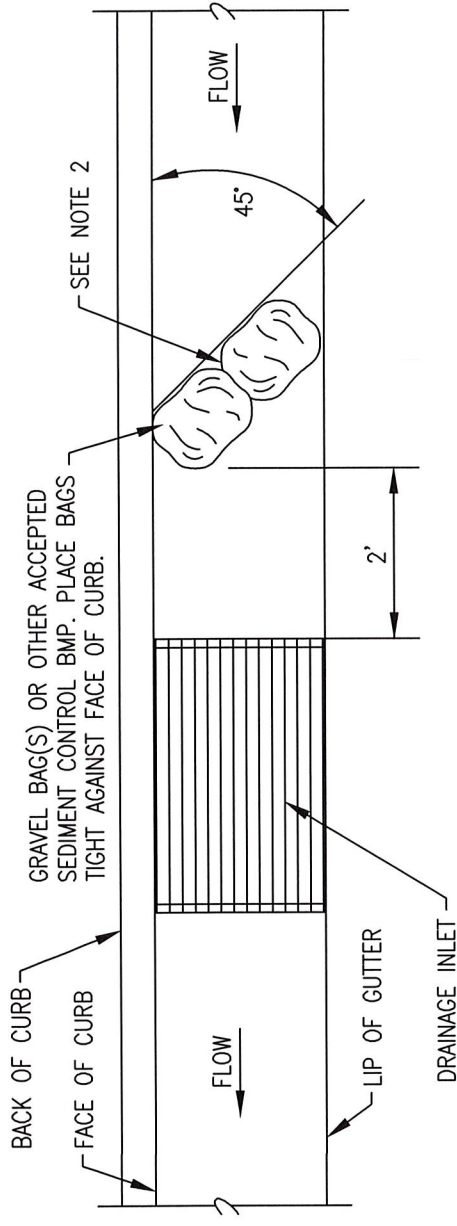

PLAN VIEW

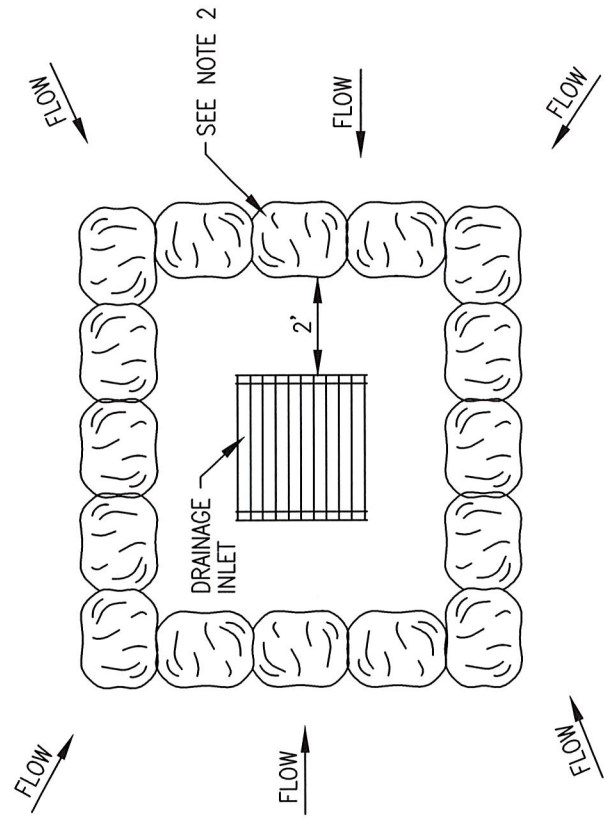

- NOTES:
- 1.) SEDIMENT TRAPPED UPSTREAM OF SEDIMENT CONTROL BMP SHALL BE REMOVED WEEKLY AND PRIOR TO A RAINFALL EVENT.
  - 2.) PLACE BMP'S TIGHTLY TOGETHER AT JOINTS TO PREVENT OR MINIMIZE SEEPAGE AT JOINTS.

*Milubert Pellet*  
 DIRECTOR, DEPT. OF WATER RESOURCES

SACRAMENTO COUNTY MUNICIPAL SERVICES AGENCY	
<b>INLET SEDIMENT CONTROL</b>	
DRAWN BY: AW SCALE: NONE DATE: REV. MAR. 2014	<b>11-7</b>

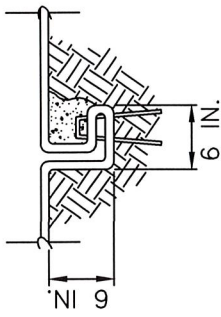

CHECK SLOT

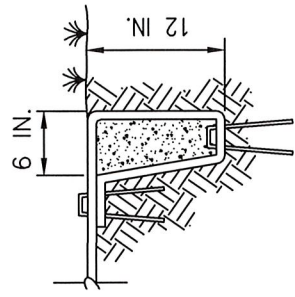

INITIAL CHANNEL ANCHOR TRENCH

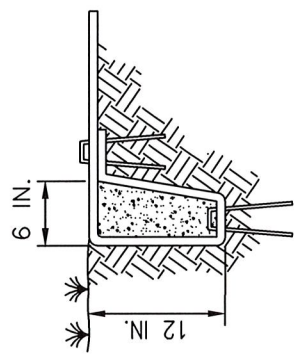

TERMINAL SLOPE AND CHANNEL ANCHOR TRENCH

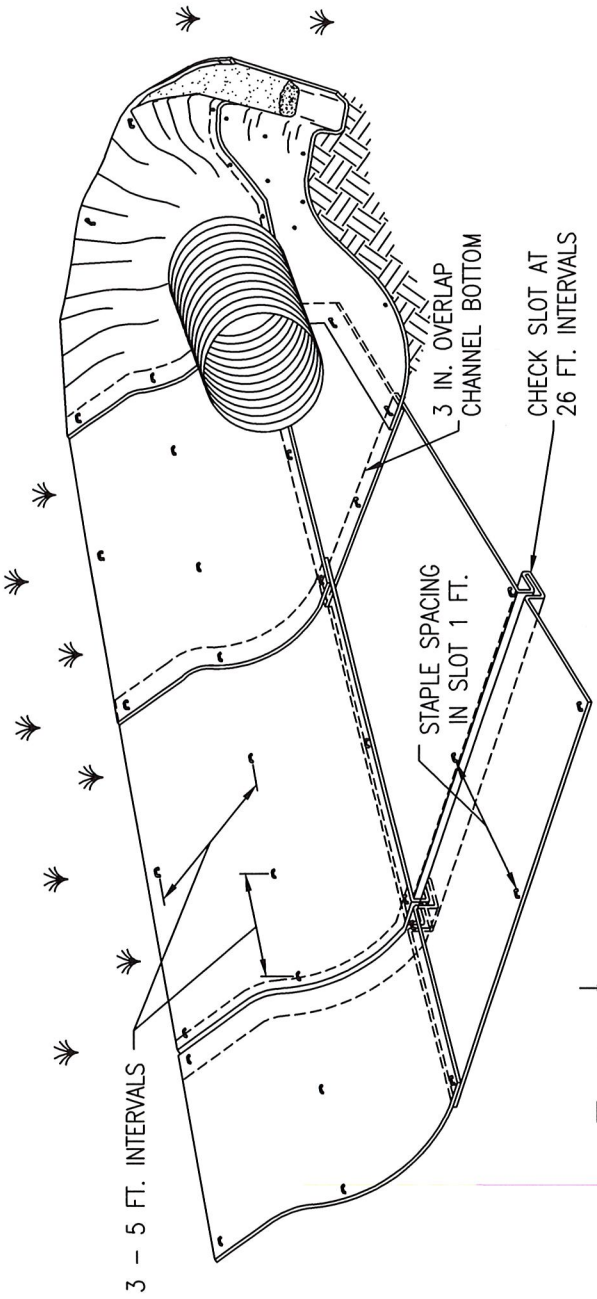

TYPICAL CHANNEL SOIL STABILIZATION

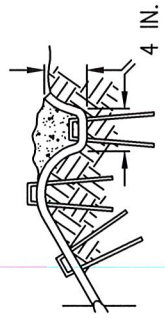

LONGITUDINAL ANCHOR TRENCH

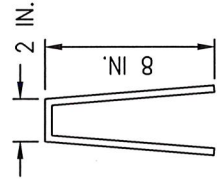

WIRE STAPLES

NOTE:  
 1.) CONSTRUCTION OF CHECK SLOTS, STAKING, STAPLING LAYOUT, AND MAT INSTALLATION ALL TO BE DONE PER MANUFACTURER'S SPECIFICATIONS.

*Michelle Altman*

DIRECTOR, DEPT. OF WATER RESOURCES

SACRAMENTO COUNTY  
 MUNICIPAL SERVICES AGENCY

**EROSION CONTROL  
 BLANKETS / MATS  
 CHANNEL INSTALLATION**

DRAWN BY: AW  
 SCALE: NONE  
 DATE: REV MAR 2014

**11-8**



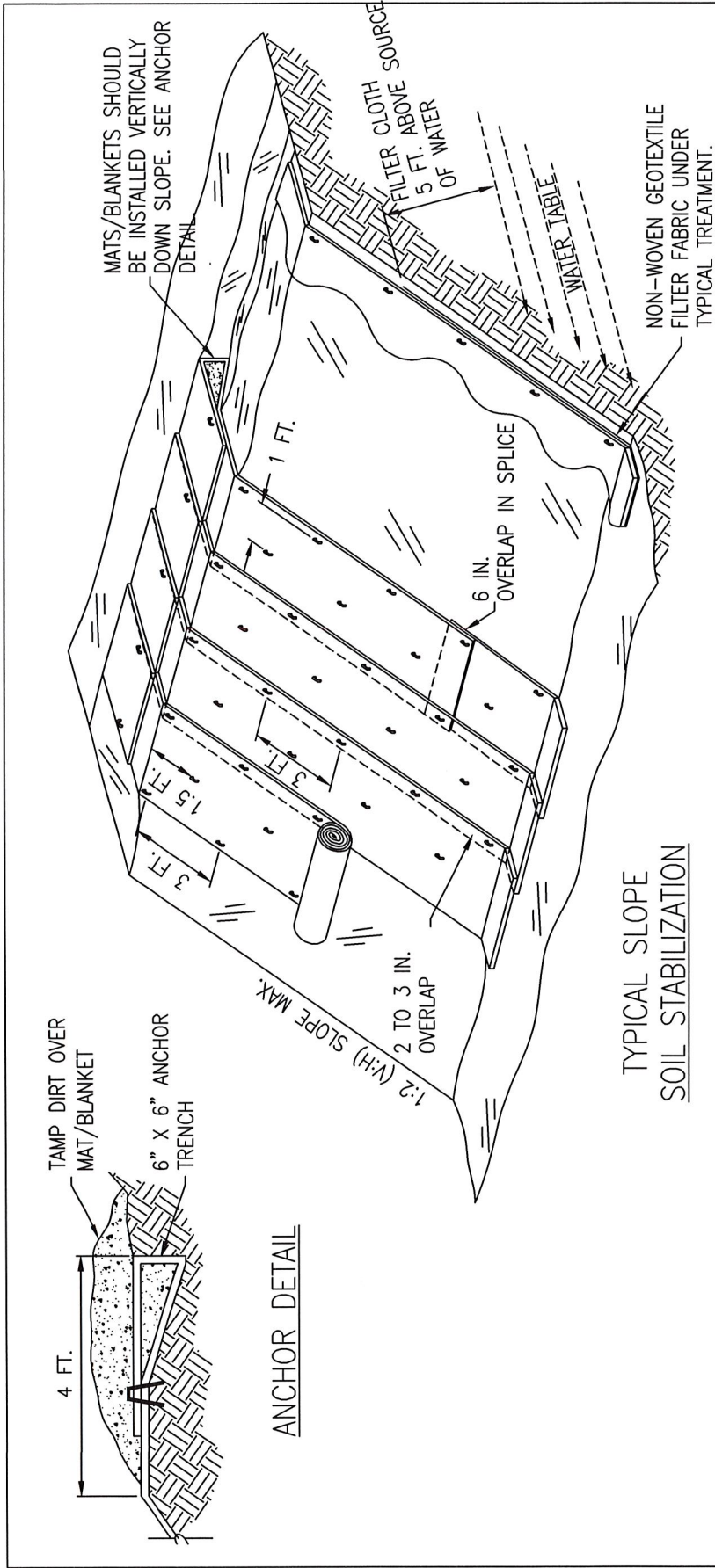

WET SLOPE LINING

NOTES:

- 1.) SLOPE SURFACE SHALL BE FREE OF ROCKS, CLODS, STICKS AND GRASS. MATS/BLANKETS SHALL HAVE GOOD SOIL CONTACT.
- 2.) LAY BLANKETS LOOSELY AND STAKE OR STAPLE TO MAINTAIN DIRECT CONTACT WITH THE SOIL. DO NOT STRETCH.
- 3.) INSTALL PER MANUFACTURER'S RECOMMENDATIONS.

SACRAMENTO COUNTY  
MUNICIPAL SERVICES AGENCY

**EROSION CONTROL  
BLANKETS / MATS  
SLOPE INSTALLATION**

DRAWN BY: AW  
SCALE: NONE  
DATE: REV. MAR 2014

**11-9**

*Michelle Galt*

DIRECTOR, DEPT OF WATER RESOURCES